

PT UTENSIL

Utensils and dishes. In one machine.



A machine for perfect cleanliness and hygiene. Perfectly coordinated accessories. Specially developed chemicals. Advice and personal support. Planning expertise and training courses. Monitoring, reporting and service. All that and more from Winterhalter.



BOTH UNDER CONTROL.

»Do you wash dishes or utensils?« In some cases the answer to this question is: »Both!« For example, when pots, pans, cooking utensils and plates have to be washed in a restaurant. To help you avoid having to purchase two machines, Winterhalter has developed the PT Utensil: It delivers consistently first-class washing results for both utensils and dishes. It doesn't matter whether you switch back and forth or wash one type of item the whole day. Regardless of whether it's pots, pans or implements. Sheet pans, GN containers and Euronorm crates, or dishes. The PT Utensil always meets the very highest standards of cleanliness, hygiene and ergonomics.

»By creating the PT Utensil, Winterhalter proves that being able to wash utensils and dishes in a single machine need not be a compromise: We have managed to meet the highest standards of cleanliness and hygiene in both application areas – even in continuous operation!«

Leonie Hengeler, INTERNATIONAL PRODUCT MANAGER

FLEXIBLE USE

Utensils, dishes or both on an alternating basis: The PT Utensil combines two applications in one machine, meeting the very highest standards of cleanliness and hygiene. This means that: You remain flexible and save yourself the need to purchase a second warewasher.

ERGONOMIC OPERATION

The PT Utensil makes washing a little easier: with a smart touchscreen display for intuitive operation and the ergonomic convenience of a passthrough dishwasher. For simple and fluid work processes – even when washing utensils.

FIRST-CLASS WASH RESULTS

No matter how stubborn the dirt is: The PT Utensil guarantees certified cleanliness and hygiene. With the powerful warewashing system and the effective quadruple filtration, you are totally prepared for every eventuality.

ABSOLUTELY RELIABLE

The PT Utensil delivers exactly what a machine needs for the daily grind of warewashing: innovative technology, high-quality workmanship, and low susceptibility to faults. A machine you can rely on completely.

OPTIONS AND ENHANCEMENTS:

WASHING WITH THE PT UTENSIL.

It is the hybrid model from Winterhalter and was developed for those who have special demands from a machine when washing dishes and utensils: The PT Utensil combines a powerful warewashing system including variable wash pressure adjustment with the ergonomics and easy operation of a passthrough dishwasher.

MACHINE SIZES

PT-L UTENSIL

- Clear entry height: 440 mm
- Dimensions (W x D x H in mm): 735 x 750 x 1,535
- Height (with hood open): 2,010 mm
- Working height: 850 mm (optional: 900 mm)
- Rack dimensions: 500 x 600 mm / 500 x 500 mm
- Special features: available with automatic hood

PT-XL UTENSIL

- Clear entry height: 560 mm
- Dimensions (W x D x H in mm): 735 x 750 x 1,655
- Height (with hood open): 2,250 mm
- Working height: 850 mm (optional: 900 mm)
- Rack dimensions: 500 x 600 mm / 500 x 500 mm
- Special features: also for GN-2/1 trays



EXAMPLES OF USE



The product illustrations are customer-specific configurations that may also include products from other manufacturers.

MIX OF DISHES AND UTENSILS

APPLICATION

Washing both dishes and utensils

REQUIREMENT

Due to limited space and cost, buying a second warewasher is not viable

SOLELY UTENSILS

APPLICATION

Washing utensils that are moderately to severely soiled

REQUIREMENT

A passthrough dishwasher is wanted, for ergonomic operation and an efficient workflow

WASHING PROGRAMMES



DISHES

Programme 1: for plates and cups or cutlery. Contact time approx. 2 minutes.



UTENSILS PLUS

Programme 3: for heavily soiled utensils. Contact time approx. 6 minutes.



UTENSILS

Programme 2: for regularly soiled cooking and work utensils. Contact time approx. 4 minutes.



SMART TOUCH DISPLAY

Ready for the future: A smart touch display is at work in the PT Utensil cockpit. With single-button operation, language-neutral interface and self-explanatory pictograms. The colour display reacts sensitively and can be operated even when wearing gloves – the surface is made of glass and is very robust. All the functions can be called up via three simple operating levels: one for users, and one PIN-protected level each for the chef and the service technician.

FILTRATION SYSTEM

Washing up is dirty and heavy work. The PT Utensil is prepared for this: with an effective quadruple filtration system. In stage 1, the tank water is passed over a strainer, which transports the dirt into the filter cylinder. In stage 2, the dirt particles are filtered out of the water. In stage 3, the filter bottom ensures that small objects such as toothpicks cannot block the pump. In stage 4, the Mediamat filters the finest dirt particles, such as coffee grounds, from the water. An additional pump protection strainer prevents mechanical damage to the pump. The result: continuously clean tank water. And the cleaner the tank water, the better the wash result.

WAREWASHING SYSTEM

The heart of the PT Utensil: Two S-shaped wash fields are at work inside the machine. Thanks to the flow optimisation and the special jet geometry, they ensure that the water is distributed evenly during cycles. This ensures first-class wash results – with a rinse water volume quantity from 2.4 litres per wash cycle. Quality down to the smallest detail: Robust stainless steel axles guarantee the best rotation and contribute to the high reliability of the PT Utensil.

HYGIENE CONCEPT

The PT Utensil Series of passthrough dishwashers stands for perfect hygiene and convenient cleaning. There is a special hygienic rack guide. The tank is deep-drawn and has a hygienic heating element. That means no nooks, crannies or concealed corners in the interior in which dirt can accumulate or deposits can form. The hygiene logbook, Thermostop function and CONNECTED WASH* provide additional safety. In other words, the PT Utensil offers an extremely high hygiene standard. This is confirmed by the DIN EN 17735 hygiene certificate.

VARIABLE WASH PRESSURE ADJUSTMENT

The PT Utensil comes with variable water pressure regulation as standard: VarioPower adjusts the wash pressure precisely to the type of dishes and how dirty they are. Plates and cups with regular soiling are washed at lower water pressure, while heavily crusted utensils are washed at higher water pressure. This ensures that heavy soiling is removed. It also means that lightweight wash items are treated gently and held securely in place.

WASTE WATER HEAT RECOVERY

A clear added advantage for the PT Utensil: The EnergyLight waste water heat recovery system is fitted as standard. The heat exchanger uses the energy from the waste water to heat the cold inlet water. The advantages: The machine heats up faster between wash cycles, resources are conserved, and energy costs fall by up to 10 %.

EXHAUST AIR HEAT RECOVERY

With the PT Utensil, the EnergyPlus exhaust air heat recovery system is available as an optional extra. In contrast to standard waste water heat recovery, an exhaust air heat exchanger is also used. It uses the energy from the hot steam inside the machine to pre-heat the cold inlet water. When you open the machine, hardly any steam escapes. And up to 15 % of energy costs are saved per wash cycle.

AUTOMATIC HOOD

Convenient and practical too: The PT-L Utensil is available with an automatic hood. The machine can be operated without effort – a real relief for dishwashing staff. The hood is closed with the simple press of a button, either via the display or an ergonomically positioned button. The wash cycle then starts automatically. At the end of the programme, the hood automatically lifts up to indicate that the wash cycle has finished.

CONNECTED WASH *

More safety and efficiency: With CONNECTED WASH, the PT Utensil can be integrated into your network and all the important operating data can be evaluated. Consequently, recommendations and actions are made that will help to optimise the washing process. Moreover, the machine status can be monitored around the clock and from anywhere in the world.

RACKS

The PT Utensil comes with a basic set of racks: The machine is supplied with a stainless steel rack for utensils and a plastic rack for dishes and trays. Additional racks and rack inserts for different wash items are also available as accessories.

A detailed overview of the PT Utensil is available on our website at:

>> www.winterhalter.com/pt-utensil

* You can find out in which countries CONNECTED WASH is currently available and what functions and options it offers at www.connected-wash.com

Cleanliness and hygiene. Every single one of our products plays its part. Together they create the perfect wash result. Welcome to the complete Winterhalter system!

WASH RACKS

They are custom-made for dishes or utensils. With their functional design they adapt precisely to the respective wash items, protecting them and preventing damage. They ensure ideal water and air circulation and fast drying. And of course they make handling and transporting wash items easier.

Wash racks are a key component of the Winterhalter complete system. We will be happy to advise you on which racks best suit your requirements. Culminating in the best solution for you.



CHEMICALS

Usually overshadowed by the machine. Often underestimated. But they have a crucial influence on the wash result: the chemicals. For this reason they are an extremely important component within the overall Winterhalter system.

We therefore established a research department with an in-house laboratory many years ago at our headquarters in Meckenbeuren. Here we develop and test formulas for a premium range of detergents and hygiene products. They are perfectly tailored to the various different wash items and types of soiling, economical to use and perfectly coordinated to the other products in the range. They work together perfectly and deliver a brilliant overall wash result.

WATER TREATMENT

Deposits. Streaks. Specks. They are »unwanted gifts from the kitchen« and the natural enemies of any restaurateur. This is because they expose poor washing quality. As limescale impairs the effect of detergent and rinse aid and damages the machine in the long-term. The problem is water quality. The solution is professional water treatment.

For example, the external softening device, the DuoMatik 3: It reduces the mineral content in hard water and delivers consistently soft water. This improves the wash result and hygiene, prevents limescale deposits and permanently protects the machine from damage. It also ensures that less detergent and rinse aid are required and that both can work as effectively as possible.



ADVICE AND PLANNING

Winterhalter is the specialist in commercial warewashing systems. Our knowledge encompasses the widest range of kitchens in the world. We know which aspects are important when it comes to washing, and what has to be taken into consideration. And: we enjoy passing this knowledge and experience on to our customers.

The aim: a perfect washing process. A big advantage of the PT Utensil is its flexibility. The machine adapts to the space you have on-site and your working processes perfectly. Which installation type offers you the best workflow? Are the inlet and outlet tables set out in a line or wrapped around a corner to save space? On which side do you want remove the clean dishes? In other words, what is the working direction? What could a heat recovery system do for you? We help you answer every single question. So that you can make the right choices when you make your investment.

Your partner, Winterhalter. Our team of advisers and planners analyse your individual on-site situation: the layout, the floor plans, the processes. We plan your estimated requirements and calculate the necessary equipment. We help you organise your washing operation, optimise the washing logistics and provide instruction and training sessions for your employees. In short: when it comes to washing up, we're always there for you. From the start. And we help you to make your washing process as professional and efficient as possible.

What can we do for you? Let's talk about it: Tel. +49 7542 402-5408 or www.winterhalter.com/contact

»We are family people!«

Down-to-earth. Forward-looking. With a focus on family. The culture and values of our family have shaped the Winterhalter company for three generations. Close to staff, customers and partners. Long-term thinking with a view to the generations to come. Taking personal responsibility – all typically Winterhalter. We are proud of our family company. And we are pleased to grow a little more every day.



Karl Winterhalter



Jürgen Winterhalter



Ralph Winterhalter

THE FIRST WINTERHALTER



It all began in 1947: Karl Winterhalter established his own company in Friedrichshafen. He started by salvaging scrap metal from the war, which he used to manufacture household goods. Cooking pots and ovens, for example. A short time later he specialised, and in 1957 launched the GS 60 model: the first commercial warewasher from Winterhalter. That was the starting signal. Since then the company has always pursued a single goal: perfect wash results as part of an efficient washing process. With this holistic approach, Winterhalter has developed from a machine supplier to the full system provider of warewashing solutions it is today.

»Products, advice, service – three factors that intertwine seamlessly at Winterhalter. And that makes our customers feel safe in the knowledge that they have the right partner for any issue relating to the washing process.«

FROM WAREWASHER TO WAREWASHING SOLUTION

In days gone by, all we needed to do was deliver the new warewasher to our customer's kitchen on a hand truck. Now it's about the development of a new, individual warewashing solution, which is perfectly coordinated with the on-site situation and the special requirements and preferences of the customer. A solution of this type is based on clear analysis and planning. To achieve this, we visualise the room layout using state-of-the-art CAD software in 2D and 3D. For a bespoke and efficient washing process.

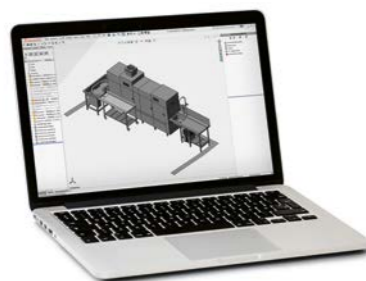

OVER **2.000**

EMPLOYEES WORLDWIDE

High quality standards. Diligence. Curiosity and ambition. These are the typical attributes of a Winterhalter employee. And with them, we have grown from a small Swabian family company into a global player: with over 40 branches worldwide and distribution partners in over 70 countries. We are proud of what we have achieved. And we are proud of each and every employee who has done their bit. So we would just like to take this opportunity to officially say »Thank you!«



OUR ACADEMY OF WASHING SCIENCE

Almost 1,000 participants per year and 250 training days worldwide: as part of our training programmes we pass on our knowledge and experience in the discipline of »warewashing«. We provide training to our own personnel as well as to our retail and service partners. Our objective: every Winterhalter customer should receive informed advice and professional support in the specific situation. Whether it's an initial informative discussion, installing a warewasher, or service and maintenance appointments.

IN-HOUSE LABORATORY FOR IMPROVED CHEMICALS

As a specialist in warewashing, do we want to rely on the products of other manufacturers? The answer to this question was an immediate and resounding »No!«. This was the moment, when our in-house research and development laboratory was born: we have been developing our own formulas for original Winterhalter chemicals for many years now, from detergents and rinse aids to hygiene products.

Good to know

As a specialist in warewashing, at Winterhalter we set high standards for ourselves: we don't just want to meet our customers' current requirements. We want to support them proactively and gain their trust for the long term. Service plays an important role here: our comprehensive network guarantees fast and professional support on site. Worldwide.

We and our service partners are there when you need us. On that you can always rely with Winterhalter.



What opportunities does new technology offer? How is our society and the world of work changing? Which trends and developments will shape commercial warewashing in the future? We find all of these questions extremely exciting. And that's why we are already working on developments that will affect us and our customers today, tomorrow and in the future. Our innovations CONNECTED WASH and PAY PER WASH, among others, demonstrate what these solutions look like.

>> www.connected-wash.com >> www.pay-per-wash.com

»See you again soon!«

Customers often own a Winterhalter warewasher for 15 or 20 years. So our customers only have to worry about disposing of their old equipment once every few decades. What's more, we take care of this ourselves. We design our machines as modular systems, so they are easy to dismantle if ever the need arises. We reduce the range of materials, use standardised construction materials and label plastic parts for easy recycling. Winterhalter warewashers have a particularly high recycling ratio thanks to these and many other measures.



MADE IN GERMANY AND SWITZERLAND

As ever, it is not simply an indication of origin, but a seal of quality: products made in Germany and Switzerland are recognised worldwide for their premium quality and reliability. For engineering, inventiveness and precision. Winterhalter is the best proof of this: in Meckenbeuren, Edingen and Rüthi, we develop and produce solutions for first-class cleanliness and hygiene. This is our promise for every single warewasher that leaves our factory.

PT UTENSIL TECHNICAL DATA

PT-L/PT-L EnergyPlus

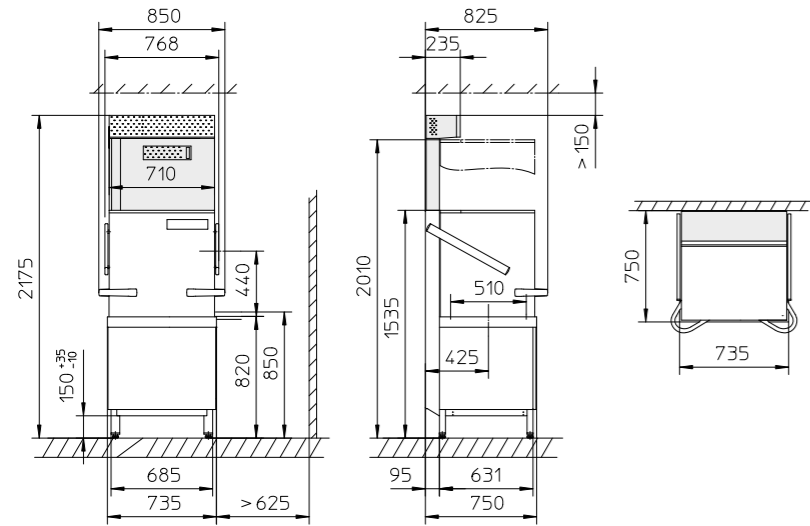

PT-XL/PT-XL EnergyPlus

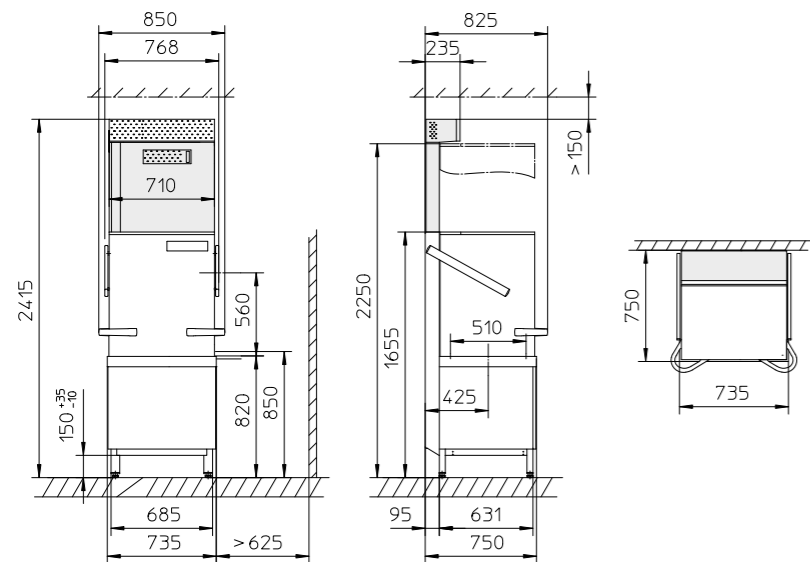

General data		PT-L UTENSIL	PT-XL UTENSIL
Tank capacity	l	36	36
Rack dimensions	mm	500 x 500 / 500 x 600	500 x 500 / 500 x 600
Clear entry height	mm	440	560
Working height *1	mm	850	850
Wash pump	kW	1.5	1.5
Noise emission	dB(A)	max. 62	max. 62
IP protection class		IPX5	IPX5
Weight net / gross	kg	142 / 158	148 / 167
– with EnergyPlus	kg	163 / 187	172 / 202
Max. inlet water temperature	°C		60 (EnergyPlus: 20)
Required flow pressure	bar / kPa		1.0 – 10.0 / 100 – 1,000
Required flow pressure EnergyPlus	bar / kPa		1.5 – 10.0 / 150 – 1,000
Tank heating	kW	2x2.5	2x2.5

Specific data

Theoretical capacity standard P1/P2/P3 *2	Racks/h	32 / 13 / 9
Theoretical capacity short programme *2	Racks/h	72
Rinse water volume per wash cycle Dishes *3	l	2.4
Rinse water volume per wash cycle Utensils *3	l	4.0
Tank temperature	°C	62
Rinse water temperature	°C	85

ELECTRICAL DATA PT Utensil, PT Utensil EnergyPlus

Mains voltage	Fuse protection	Total connected load Boiler heating 6.4 kW *4
380V/3N~/50 Hz	16A	7.3 kW
380V/3N~/60 Hz		
400V/3N~/50 Hz	25A/32A	11.5 kW
400V/3N~/60 Hz		
415V/3N~/50 Hz	15A/16A/20A	8.6 kW
415V/3N~/60 Hz		
200V/3~/50 Hz	25A	6.8 kW
200V/3~/60 Hz	32A	8.2 kW

*1 Working height optionally also 900 mm instead of 850 mm. The vertical dimensions then increase by 50 mm.

*2 Depending on local conditions (inlet water temperature / electrical supply), the values stated here may be reduced.

*3 Non-binding information. The actual rinse water volume may vary depending on the on-site conditions.

*4 The actual capacity varies depending on the mains voltage.

»In this brochure, we have presented our PT Utensil: its product features, application options, and what sets it apart. However, we are yet to present you with our strongest argument: the positive experiences of our satisfied customers. Simply ask them the next time you see a PT Utensil installed anywhere. There is no better aid to making your decision.«

Jürgen and Ralph Winterhalter